



Simon Rodway reviews this
1/10th 4WD Off Roader
from Hirobo

Nice design and a lot of attention to detail makes the Alien a real winner.

"You want me to do what?" Dave Pearson, sometime Editor of Radio Race Car is renowned for his wicked sense of humour and sharp wit and when he rang me to ask me to do a review on an off road buggy, I thought I was on the receiving end of one of his merry japes! I am an aeroplane man and have never built a car let alone driven one! When he told me it was called the Alien, I had visions of a close encounter of the fourth kind! But no, he was serious and after I had made sure that he wasn't crossing his fingers behind his back, I went and collected the box. Aren't I glad I did!

The Alien is a mid engined, 4WD 1/10th scale off roader produced from Hirobo and distributed in the UK by MacGregor Industries. The front and rear gearboxes are connected by a belt drive that is totally enclosed within a neat cover that ensures that

no muck, gravel or water is allowed to enter the compartment and contaminate the drive train. Both gearboxes are pre-assembled and the initial construction is both straight forward and quick — even I was able to assemble the differential units, motor mount plates, front and rear axle mounts and the main chassis and belt cover in about half an hour!

Being an aeroplane man, my initial reaction on opening the box was one of surprise. Apart from the sealed 'brister' pack (it's worth buying one

ALIEN MID 4.

Coil over oil dampers at all four corners.

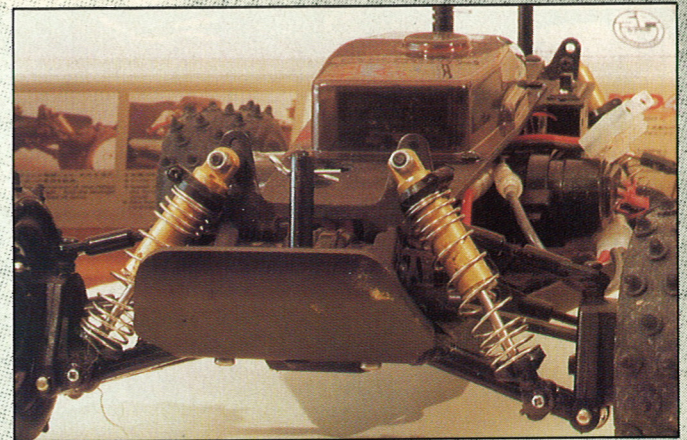

Front suspension is fully adjustable.

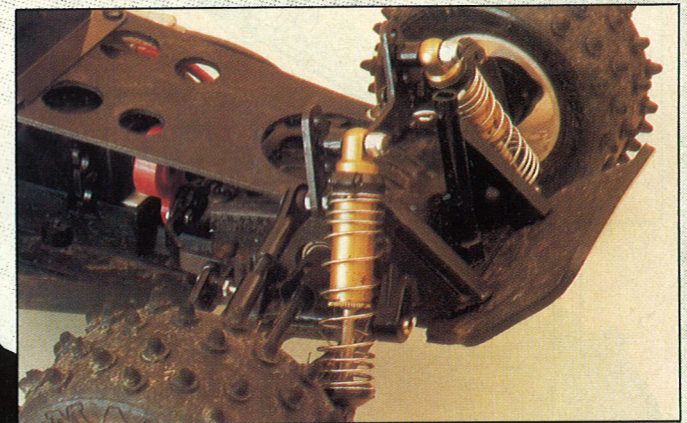

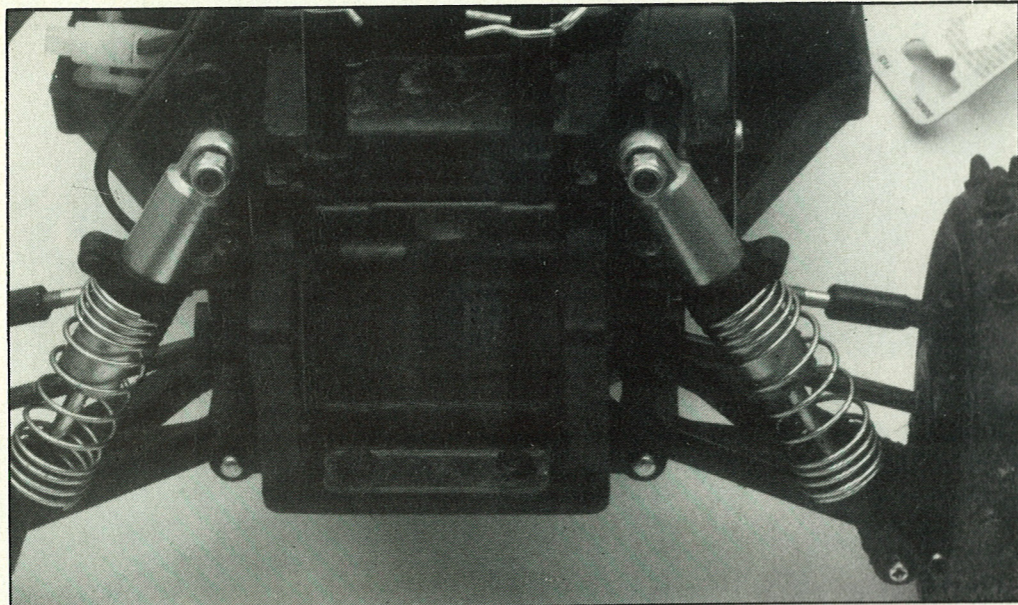

① Main drive belt runs full length and is protected by a cover which also aids torsional stiffness.

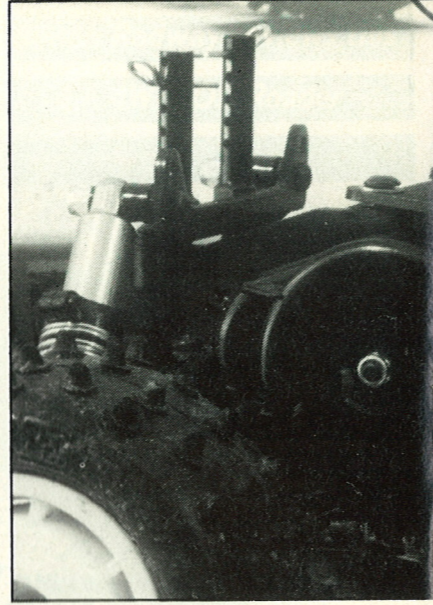

② Coil over oil units are fully adjustable for length and tension.



③ Neat engine cover allows the minimum of muck and water to come in contact with the main drive gears.

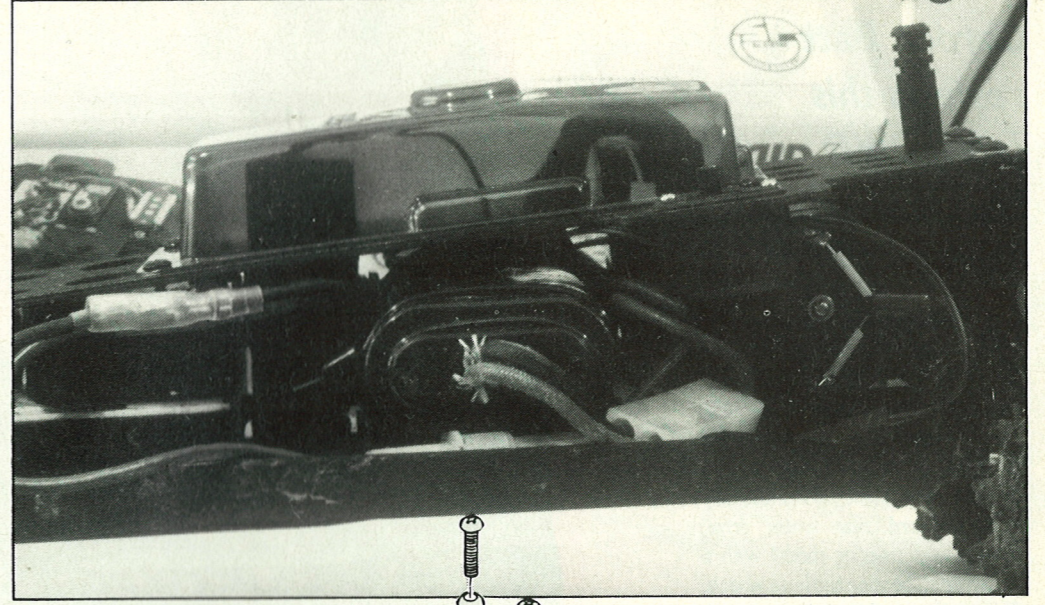

④ Top mounted radio deck — undo six screws, disconnect the fly leads and you have access to everything.

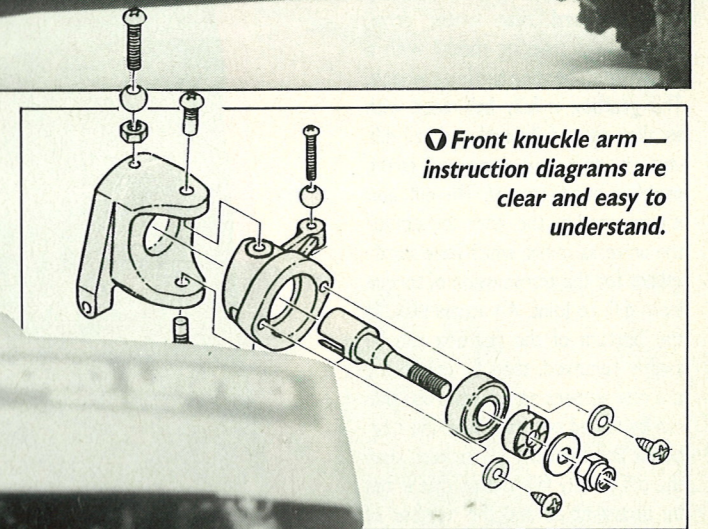
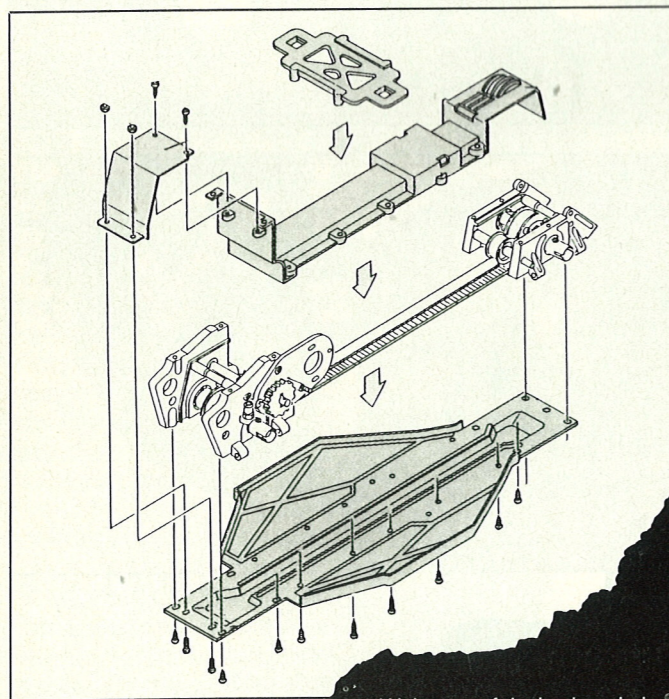

⑤ Front knuckle arm — instruction diagrams are clear and easy to understand.

of these just for the fun of reading the Japanese English) the whole kit was contained in sealed plastic bags and cardboard boxes. Deciding that discretion was the better part of valour, I relented and read the instructions carefully before starting in on the build itself. This proved to be quite a good move since it gives you a clear idea of what comes next — the building sequence should be followed pretty carefully. The instruction book is excellent — where you have trouble deciphering the English, the clear and detailed illustrations will always point you in the right direction.

With most of the hard work done for you, construction is a fairly straight forward 'fit A to B' building job. However, do be sure that you use the right bits at the right time — for example, there are two sizes of ball joint used in the suspension set up and it is easy to use the wrong one in the wrong place and then wonder what's gone wrong when things don't fit! Keep things simple and only open each bag as you reach that part of the construction. The suspension itself consists of 'coil over oil' units that are standard at all four corners. Putting them together is simple but remember to let the units stand for a while after you have filled them with oil so that all the air escapes before you fit the pistons — if you don't, the dampers will be, at best sticky, or at worst they

will jam in one position. The dampers are fully adjustable to suit a particular use making the Alien a versatile buggy for many different terrains.

The Alien is supplied with a speed controller that gives both forward and reverse on the motor. This is mounted on the top deck (of which more in a minute) and is servo driven. The controller has two methods of overheating protection that are built into the unit as a whole during construction. The instructions go to great lengths to emphasise the importance of these (not surprisingly if you've ever seen a short circuited Nicad pack in full swing!) and the build schedule should be rigidly followed. I'm a coward and decided to use an NEA 950 FET electronic controller that fitted perfectly into the hole provided in the top plate for the controller drive servo.

The top mounted radio deck is probably one of the highlights of the whole package. If you built the Alien as per the instructions, this deck will

have the receiver, speed controller and controller drive servo mounted on it. If you use an electronic controller, it will be mounted in the top plate along with the receiver. The inspired thinking behind this set-up is that by undoing six screws and disconnecting two bullet connectors, a multi block and the servo leads, you can gain access to literally everything that is serviceable. Taking only a minute to reach all these items has got to be one of the biggest pluses for the Alien since maintenance — especially trackside — is a piece of cake.

Ancillaries such as tyres and wheels are all of good quality being cyano'd together once positioned correctly. The battery pack is held in place with plastic ties and the body mounting pylons are screwed down onto the chassis. The body shell supplied as it came out of the mould and you have to cut it to shape very carefully. Painting is done as usual from the inside and this gives you the chance to personalise

your own Alien in your racing colours. The instructions state that you should use paints that are compatible with polycarbonate — this is good advice! If you do use other paints, do remember that you can't use cellulose based paints on top of enamel paints — not that I would do that sort of thing!!! Finally, the sticker sheet provided is comprehensive and gives plenty of choice including a sticker for your name and frequency.

The Alien Mid 4 was great fun to build but it wasn't until I came to drive it that I realised what it had all been

for. As a performer, the Alien is excellent and there is very little in the way of rough terrain that will get in its way. Being mid engined it is very stable and therefore reluctant to overturn and the centre of gravity is correspondingly low which gives good cornering ability. As time has gone on I have pressed my Alien harder and harder, trying to find its limits with no luck. Whenever I rub my hands with glee and say "It'll never manage that", I'm proved wrong. Living as I do, on the Malvern Hills, I have plenty

of rough country around me but short of throwing it off the top, I'm fast running out of ideas!

As an off road buggy, I am most impressed with the Alien and now that I have one, I am starting to get hooked. Watch this space . . . ○