

Hirobo's out of this world new car is reviewed by Radio Race Car

A little over eighteen months ago Hirobo released a car onto the U.K. market called the Zerda. Initially, it seemed that "Joe Racing Public" had let the Zerda slip by without a second glance, maybe the word glance was the crux of the problem, because a glance at this car would undoubtedly leave a majority of people cold. The lack of bodyshell, did give the Zerda an unusual look to say the least. However, technically the Zerda was a small quantum leap ahead of anything else available, as those drivers who purchased the car soon found. So why are we babbling on about the Zerda, when this review is supposed to be based on the Alien? The reason is simple and in two parts, firstly the Alien is another car from Hirobo with a strange bodyshell, you'll either love it or hate it, but don't let the bodysell sway your decision, take a look at the rest of the car, take in all

the winning points and the clever bits, then make up your mind.

Somewhere In The Depths of Space

The Alien is a mid engine, 4wd 1/10 scale off roader from Hirobo. All four wheels are driven by a belt linking the front and rear gearboxes. Both gearboxes are fitted with bevel gear type differentials, pre-assembled for fast assembly, in fact both gearboxes and the drive belt cover were assembled in record time, about twenty minutes. Once the drive belt cover is in place, the belt is completely sealed ensuring that no mud, grit or water is allowed to enter either of the Aliens gearboxes.

Suspension and Shockers

All four corners of the Alien are held up by common suspension units, this will make

The Aliens running chassis, note the clear inspection area to the gearbox.

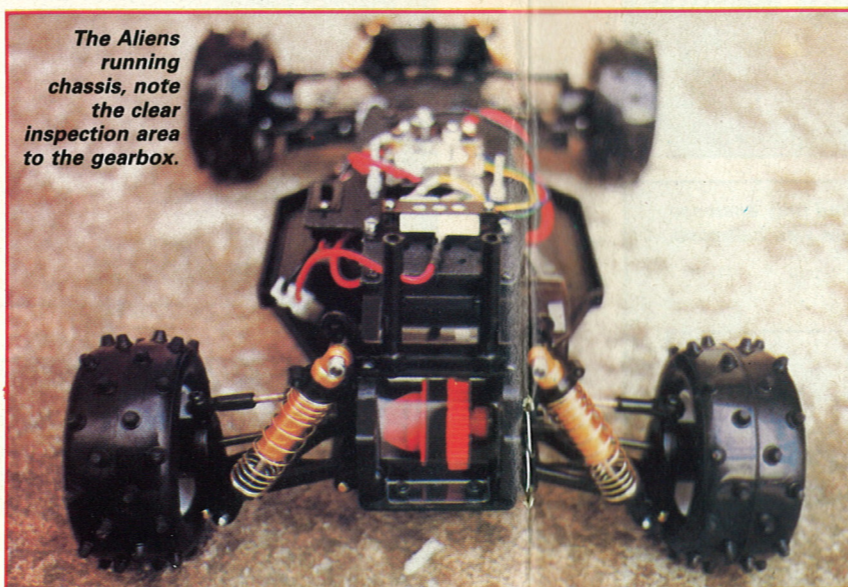

The steering end, handling in kit form is very good with a huge amount of lock available.

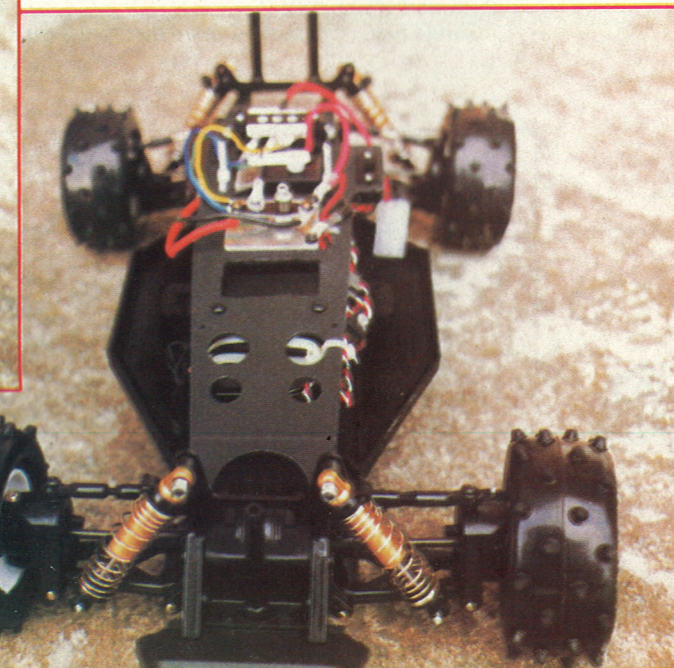

for an easy list of spares and aid any trackside maintenance that needs to be carried at. All four lower wishbones are held firmly in place using hinge pins, as are all uprights. All suspension tie bars act as wheel camber adjustment points allowing the car to be adjusted to suite a variety of track surfaces. Toe in can also be adjusted

by adjusting both track rods. All four shock absorbers are coil over oil units which again are pre-assembled ex-factory, apart from the front units being shorter there is no internal difference, again a good point to bear in mind when spares need to be purchased. In general, the coil over oil units work very well indeed and are three

ALIEN MID 4



way adjustable at both front and rear, again adding to the overall dialability of the car. All four units are nicely finished off with a gold anodised effect.

Radio Communication

The one point that really stands out on the Alien as a major plus is the radio deck, this

is a second chassis that sits above its structural counterpart and contains all the electric and radio components, with the exception of the steering servo. Again this is a real gem of wisdom, the type of innovation that should be used on all cars, why? Well, by releasing six screws and uncoupling three flyleads, electric and mechanical

components can be very effectively separated, making maintenance both at home and especially trackside simple and quick to perform. A three speed forward and one reverse controller is employed and coupled to a temperature fuse that is situated in the event of your car becoming stuck, or

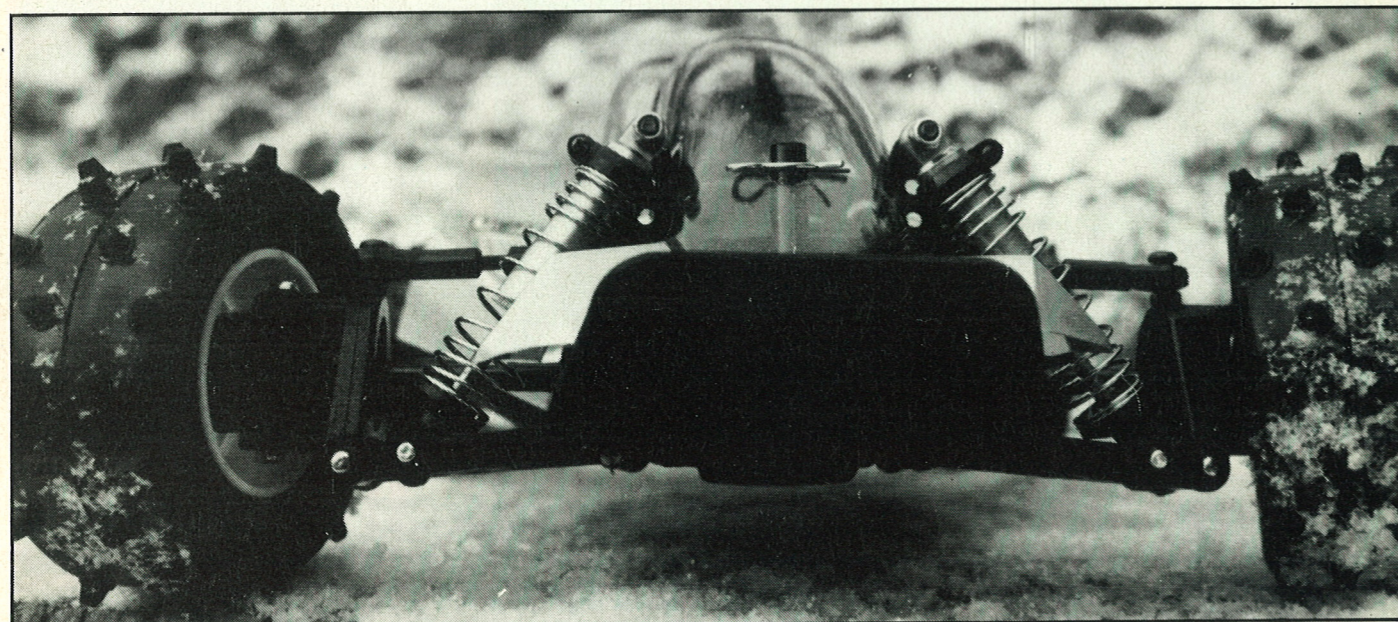

Exploded views show front and rear gearboxes and fully enclosed drive belt, note that all drive belt tensioners are also ballraced.

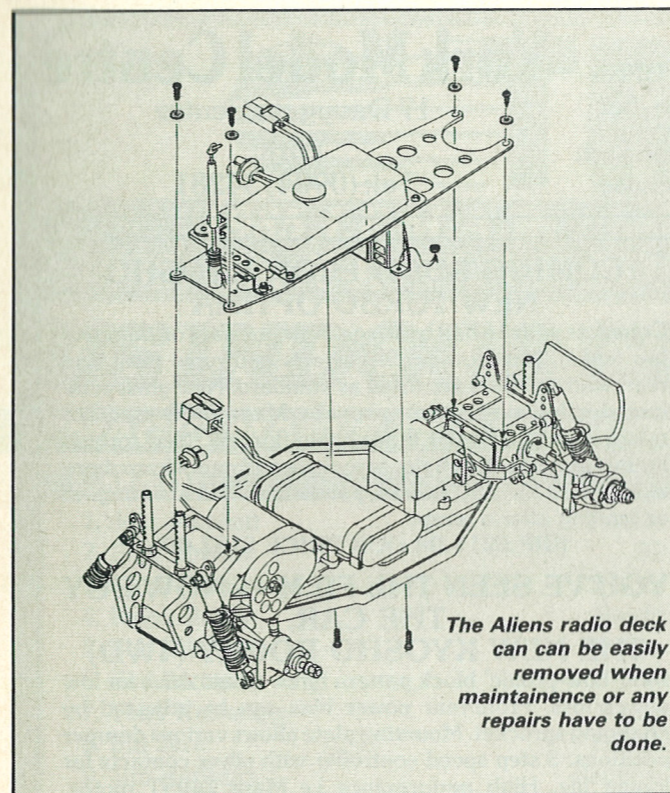
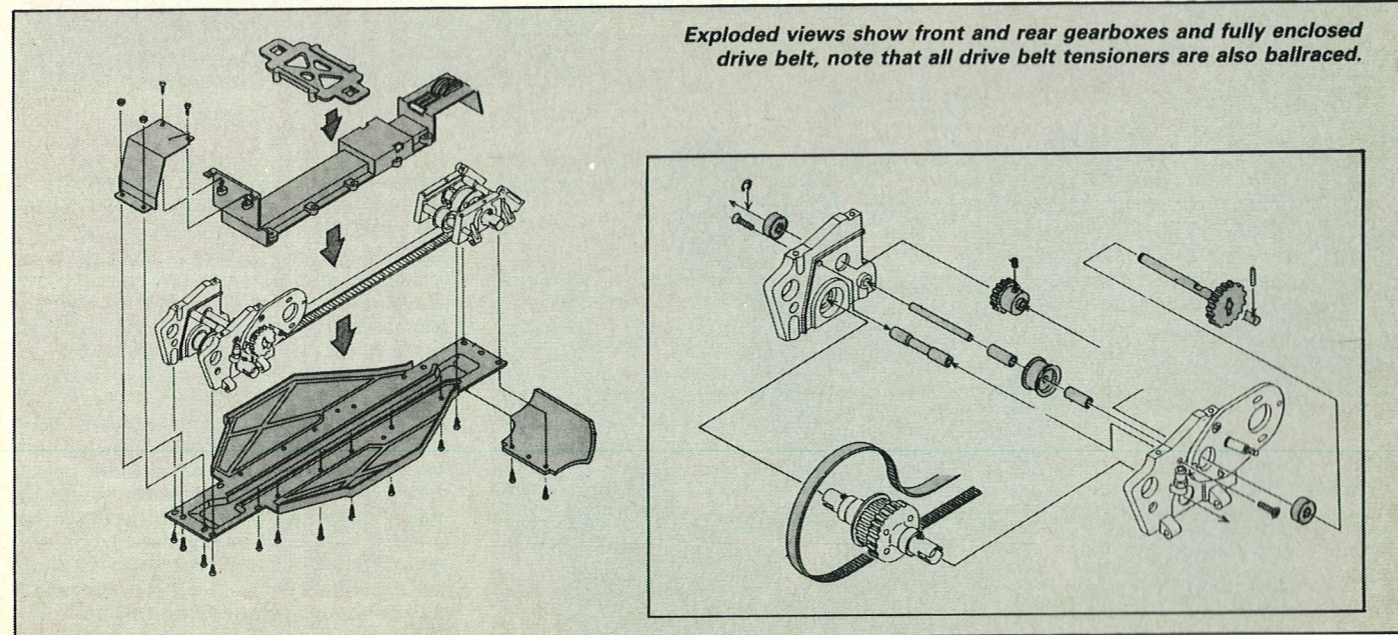

The Aliens radio deck can be easily removed when maintenance or any repairs have to be done.

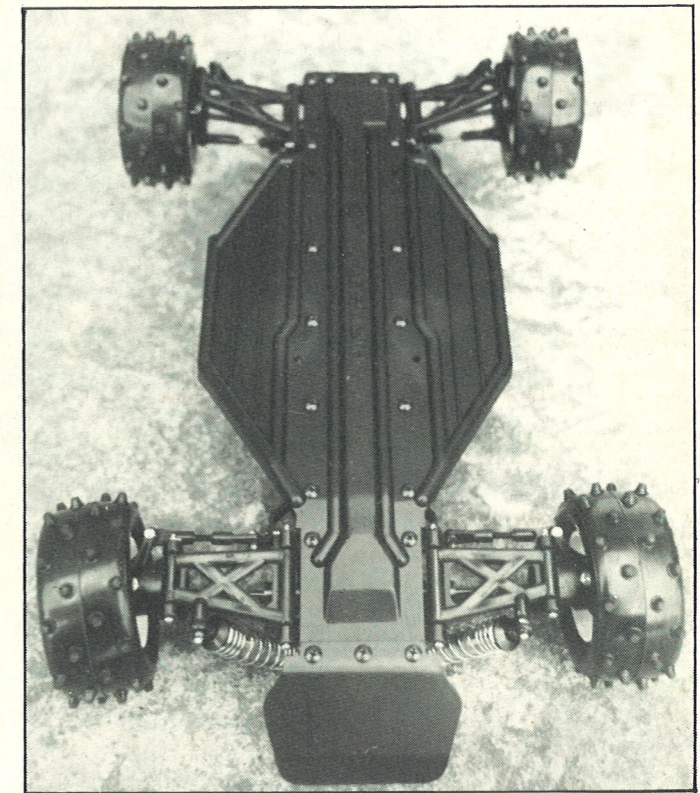

Chassis is full length giving good all round protection to the drive belt and both gearboxes

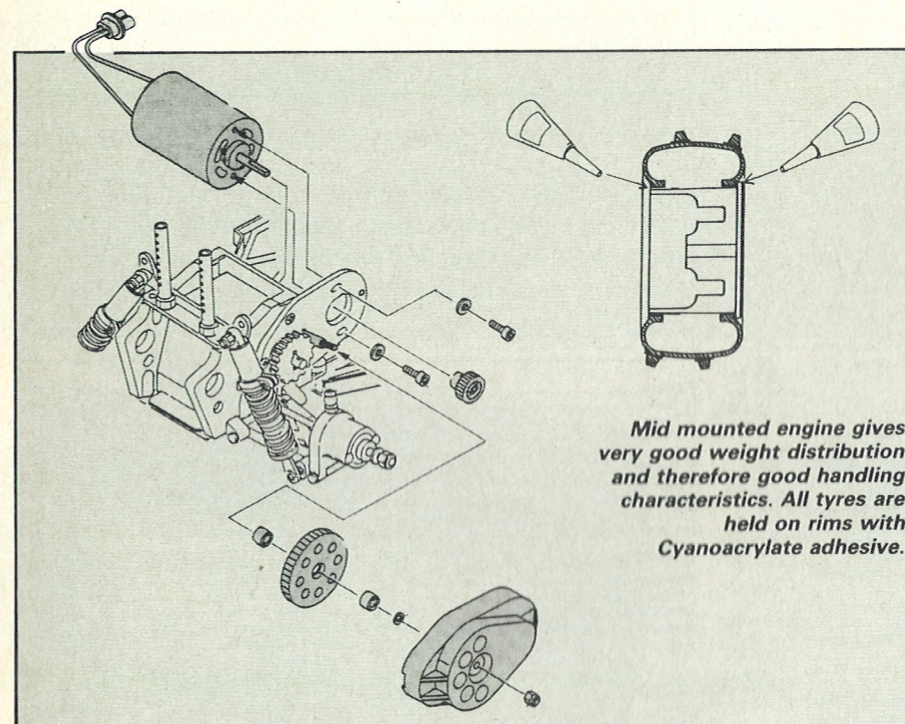

Mid mounted engine gives very good weight distribution and therefore good handling characteristics. All tyres are held on rims with Cyanoacrylate adhesive.

jammed the inexperienced driver will not do any permanent damage by holding the throttle open until something expensive starts to burn.

Summary

The Alien is fast, in fact very fast, this is possibly due to the fact that the car is supplied in standard form with no less than fourteen ballraces, these make the Alien both smooth to drive and silent in operation. The Aliens roadholding characteristics are in keeping with most out of the box cars, that is acceptable but with a little tampering could be made better, if anything just a simple replacement of the kit oil with some a little less viscous would work wonders, then there's that love it or hate it curvaceous bodyshell that really stands out and draws a reaction one way or other, that has got to be better than scant indifference no matter which way you look.

All in all, the Alien has got to be a car to watch if it hits the circuits this year, it is fast, manoeuvrable, will be easy to keep running trackside, and there's always one thing any owner driver can be sure of, the Alien will always turn heads.

